

Mast Specification

25DE/LE-7

Mast Type	Maximum Fork Height	Overall Height (Lowered)	Free Lift Height			Tilt Angle		Load capacity without Side shift		Load capacity with Integral Side shift		Truck Weight (Unloaded)				
			With Load Backrest	Without Load Backrest	Without Load Backrest (3/4-SPOOL)	Fwd	Bwd	500mm LC	500mm LC	500mm LC	500mm LC	Single Tire		Double Tire		
												mm	mm	mm	deg	deg
2 Stage Limited Free Lift	V300	3,000	2,040	155	155	155	6	10	2,500	2,500	2,500	2,500	3,815	3,732	3,936	3,853
	V330	3,300	2,190				6	10	2,500	2,500	2,490	2,500	3,835	3,752	3,956	3,873
	V400	4,000	2,590				6	10	2,500	2,500	2,360	2,440	3,904	3,821	4,025	3,942
	V450	4,500	2,890				6	6	2,400	2,490	2,270	2,350	3,977	3,894	4,098	4,015
	V500	5,000	3,140				6	6	2,310	2,400	2,190	2,260	4,014	3,931	4,135	4,052
2 Stage Full Free Lift	VF295	2,950	2,040	860	1,314	1,314	6	6	2,500	2,500	2,500	2,500	3,851	3,768	3,972	3,889
	VF325	3,250	2,190	1,010	1,464	1,464	6	6	2,500	2,500	2,480	2,500	3,884	3,801	4,005	3,922
	VF345	3,450	2,290	1,110	1,564	1,564	6	6	2,500	2,500	2,450	2,500	3,914	3,831	4,035	3,952
3 Stage Full Free Lift	TF430	4,300	2,040	860	1,314	1,175	6	6	2,430	2,500	2,290	2,370	3,983	3,900	4,104	4,021
	TF450	4,500	2,140	960	1,414	1,325	6	6	2,390	2,470	2,250	2,330	4,005	3,922	4,126	4,043
	TF470	4,700	2,190	1,010	1,464	1,325	6	6	2,360	2,430	2,220	2,300	4,019	3,936	4,140	4,057
	TF500	5,000	2,290	1,110	1,564	1,425	6	6	2,310	2,380	2,170	2,250	4,041	3,958	4,162	4,079
	TF550	5,500	2,490	1,310	1,764	1,780	6	6	2,230	2,290	2,090	2,170	4,145	4,062	4,266	4,183
	TF600	6,000	2,690	1,510	1,964	1,875	6	6	2,150	2,200	2,010	2,090	4,145	4,062	4,266	4,183

30DE/LE-7

Mast Type	Maximum Fork Height	Overall Height (Lowered)	Free Lift Height			Tilt Angle		Load capacity without Side shift		Load capacity with Integral Side shift		Truck Weight (Unloaded)				
			With Load Backrest	Without Load Backrest	Without Load Backrest (3/4-SPOOL)	Fwd	Bwd	500mm LC	500mm LC	500mm LC	500mm LC	Single Tire		Double Tire		
												mm	mm	mm	deg	deg
2 Stage Limited Free Lift	V300	3,000	2,040	155	155	155	6	10	3,000	3,000	3,000	3,000	4,223	4,139	4,344	4,260
	V350	3,300	2,190				6	10	3,000	3,000	2,950	3,000	4,244	4,160	4,365	4,281
	V400	4,000	2,590				6	10	2,970	3,000	2,790	2,870	4,315	4,231	4,436	4,352
	V450	4,500	2,890				6	6	2,850	2,940	2,680	2,760	4,390	4,306	4,511	4,427
	V500	5,000	3,140				6	6	2,750	2,830	2,590	2,660	4,428	4,344	4,549	4,465
2 Stage Full Free Lift	VF295	2,950	2,040	860	1,314	1,314	6	6	3,000	3,000	3,000	3,000	4,281	4,197	4,402	4,318
	VF325	3,250	2,190	1,010	1,464	1,464	6	6	3,000	3,000	2,950	3,000	4,316	4,232	4,437	4,353
	VF345	3,450	2,290	1,110	1,564	1,564	6	6	3,000	3,000	2,870	2,960	4,346	4,262	4,467	4,383
3 Stage Full Free Lift	TF430	4,300	2,040	860	1,314	1,175	6	6	2,850	2,940	2,690	2,760	4,437	4,353	4,558	4,474
	TF450	4,500	2,140	960	1,414	1,325	6	6	2,800	2,890	2,650	2,720	4,462	4,378	4,583	4,499
	TF470	4,700	2,190	1,010	1,464	1,325	6	6	2,760	2,850	2,610	2,680	4,476	4,392	4,597	4,513
	TF500	5,000	2,290	1,110	1,564	1,425	6	6	2,700	2,790	2,550	2,620	4,499	4,415	4,620	4,536
	TF550	5,500	2,490	1,310	1,764	1,780	6	6	2,600	2,690	2,460	2,520	4,551	4,467	4,672	4,588
	TF600	6,000	2,690	1,510	1,964	1,875	6	6	1,960	2,590	1,850	2,430	4,613	4,529	4,734	4,650

35DE/LE-7

Mast Type	Maximum Fork Height	Overall Height (Lowered)	Free Lift Height			Tilt Angle		Load capacity without Side shift		Load capacity with Integral Side shift		Truck Weight (Unloaded)				
			With Load Backrest	Without Load Backrest	Without Load Backrest (3/4-SPOOL)	Fwd	Bwd	500mm LC	500mm LC	500mm LC	500mm LC	Single Tire		Double Tire		
												mm	mm	mm	deg	deg
2 Stage Limited Free Lift	V300	3,000	2,040	155	155	155	6	10	3,500	3,500	3,500	3,500	4,595	4,512	4,716	4,633
	V350	3,300	2,190				6	10	3,500	3,500	3,380	3,470	4,616	4,533	4,737	4,651
	V400	4,000	2,590				6	10	3,500	3,500	3,270	3,350	4,687	4,604	4,808	4,725
	V450	4,500	2,890				6	6	3,330	3,420	3,140	3,220	4,762	4,679	4,883	4,800
	V500	5,000	3,140				6	6	3,210	3,290	3,030	3,100	4,800	4,717	4,921	4,838
2 Stage Full Free Lift	VF295	2,950	2,040	860	1,314	1,314	6	6	3,500	3,500	3,500	3,500	4,653	4,570	4,774	4,691
	VF325	3,250	2,190	1,010	1,464	1,464	6	6	3,500	3,500	3,410	3,500	4,688	4,605	4,809	4,726
	VF345	3,450	2,290	1,110	1,564	1,564	6	6	3,500	3,500	3,360	3,440	4,718	4,635	4,839	4,756
3 Stage Full Free Lift	TF430	4,300	2,040	860	1,314	1,175	6	6	3,320	3,410	3,140	3,210	4,809	4,726	4,930	4,847
	TF450	4,500	2,140	960	1,414	1,325	6	6	3,270	3,360	3,090	3,160	4,834	4,751	4,955	4,872
	TF470	4,700	2,190	1,010	1,464	1,325	6	6	3,220	3,310	3,050	3,120	4,848	4,765	4,969	4,886
	TF500	5,000	2,290	1,110	1,564	1,425	6	6	3,150	3,240	2,990	3,050	4,871	4,788	4,992	4,909
	TF550	5,500	2,490	1,310	1,764	1,780	6	6	2,820	3,120	2,690	3,940	4,923	4,840	5,044	4,961
	TF600	6,000	2,690	1,510	1,964	1,875	6	6	1,810	3,010	1,700	2,830	4,985	4,902	5,106	5,023

※ : Standard

25/30/ 35DE/LE-7

Internal Combustion Diesel, LPG Engine Forklift Truck



Low fuel consumption as well as high durability!

Try excellent cost-effectiveness unique to 35DE/LE-7

PRODUCT FEATURES OVERVIEW

PERFORMANCE UP

- Dramatic TCO saving – Fuel efficiency increased by 12%, Lift performance improved by 34%
- Cooling performance improved by 10% – Reliability and durability of power train improved
- Engines from Mitsubishi and Nissan with confirmed capability, durability, and cost – effectiveness in the markets
- Transaxle with capability and durability applicable to heavy-duty operating environments
- Fully hydraulic steering system characterized by easy operation and agile, precise response

SAFETY UP

- LED working lamp guaranteeing clear field of vision during operation indoors and at night
- Operator Position Sensing System (OPSS) – Limiting driving, lifting, and tilting **Option**
- Ensuring a wide rear field of view – Panorama, RH and LH side mirrors applied by default
- Fork safety feature – Maintaining safety in case of rupture of mast hydraulic line during operation
- Rear grip bar & horn guaranteeing convenience and safety of driving during backward movement **Option**

12% ↑ Max. 34% ↑ 10% ↑

Fuel efficiency
(Dissel model only)

Lifting performance
(Dissel model only)

Cooling performance
(Dissel model only)

ECONOMICAL PERFORMANCE



CONVENIENCE UP

- Cockpit design by applying ergonomic design providing consistent comfort
- MCV lever with deck-mounted structure to minimize movement of the driver's arms
- Hood insulation reducing noise and heat introduced into the cockpit
- Grammer full-suspension deluxe seat including cushion-height adjustment function **Option**
- Standard tile cylinder cover for keeping the leg room clean, preventing the inflow of dust into the cockpit during cabin mounting
- Polyurethane floor mat reducing vibration and noise to the operator

SERVICE UP

- Side cover and floor plate with tool-less structure to reduce operating hours
- Mission controller and filter mounted on top of transmission
- Plastic sub-bonnet configuration exclusive for radiator maintenance
- Fuse box in automobile style arranged on the front of the dashboard considering the frequent maintenance jobs
- Configuring the rear cover by default for preventing the inflow of foreign substances into the bottom of the engine radiator
- LPG balance alarm system by making use of the pressure difference inside the tank **Option**

ENVIRONMENT FRIENDLY
GREAT PRODUCTIVITY, DURABILITY

PERFORMANCE ^{UP}

Low fuel consumption
as well as high durability!

Try excellent cost-effectiveness
unique to **35DE/LE-7**



35DE/LE-7

Transaxle with high durability and environmental adaptability

High capacity clutch pack and torque converter with high torque conversion efficiency is applied to the transmission of power shift mode of single gears forward and backward to perform successfully the heavy-duty operation with push mode and driving on poor roads. Axle applied with technologies of TCM demonstrates high durability and braking power and employs shoe brake with low maintenance cost.



TCO saving - Higher fuel efficiency

Applying engine in a size sufficient for flexible operation in case of variation of loads with top power and displacement among the same class and optimized design for mast operation speed improves the fuel efficiency of the diesel-engine forklift truck up to 10%; thus dramatically improving TCO.

Fuel efficiency
(Dissel model only)

12% ↑

Heat dissipation capability - Improved power train reliability

The heat dissipation capability of transmission is improved by 10% by applying aluminum radiator with high durability and heat dissipation capability, and the cooling fan consists of seven blades that yield the effects of reducing engine noise and increasing air-blowing mass.



Cooling performance
(Dissel model only)

10% ↑

Optimized mast operation speed

Mast operation capability is significantly improved compared to competing models by combining the load sensing function of optimized priority valve and the highest torque of engine among competing models, with design features such as low and stable center of gravity of the body.

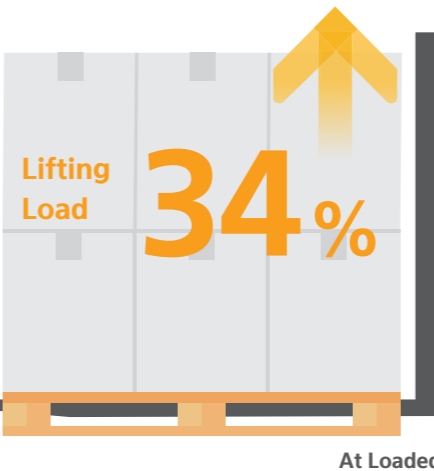

Fully hydraulic power steering

Fully hydraulic power steering without mechanical linkage between steering wheel and steering cylinder and boosting of operability of the wheel by the hydraulic pump reduce the work fatigue of the operator with easy steering operation and agile, secure response.



Engine qualified in terms of reliability and cost-effectiveness in the markets

S4S Engine & GK25 Engine are the main stream engines chosen by a number of forklift truck makers leading the forklift truck markets and are products qualified in terms of reliability and cost-effectiveness as well as serviceability.

① **S4S Diesel Engine** : EU emission Stage 3A, Turkey emission Regulation R96 have been satisfied.

② **GK25 LPG Engine** : Low fuel consumption, less noise and vibration and installer IMPCO LPG fuel system.

* Bi-Fuel (Gasoline/LPG) **Option**

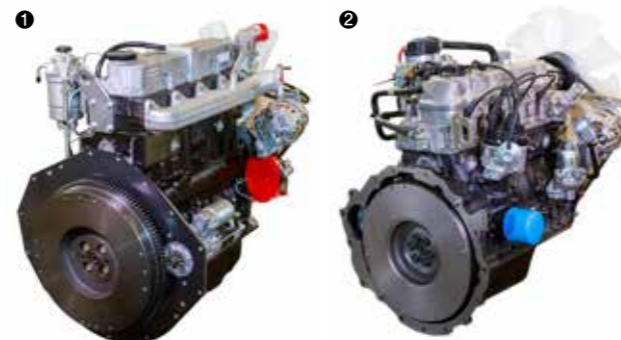

	S4S Diesel Engine	GK25 LPG Engine
Engine Power (kw/rpm)	35.3/2,250	35.0/2,550
Max Torque (kg·m/rpm)	18.0/1,700	1.7/1,600
Displacement (cc)	3,331	2,488

ENHANCED SAFETY

SAFETY & CONVENIENCE UP

Utmost importance of safety and convenient operation

Diverse incident prevention functions and consistent convenience are provided

COCKPIT, A SPACE WHERE OPERATION EFFICIENCY IS ENSURED

As a very important space for ensuring operation convenience and safety, the cockpit is equipped with ergonomic features such as **cluster with wide visibility**, position-adjustable steering wheel and seat, deck-mounted MCV lever, prompt and responsive pedal, and wide working visibility.

Deck Mount MCV lever

The deck-mounted MCV lever has a feature that reduces movements of the arms of the operator compared to the dashboard-mounted type. In addition, the levers are arranged in the radial direction around the elbow to improve convenience of operation further.



Hood insulation & floor mat

The insulation inside the hood reduces heat and noise from the engine to the cockpit. Furthermore, the polyurethane-foam floor mat reduces vibration and noise from the truck body to provide a pleasant operating environment.



Safety – Lamp & Mirror

LED work lamp and turn signals are installed by default to ensure brighter field of vision and guidance of movement direction of forklift truck during operation in dark indoor space and at night. Panorama and RH and LH side mirrors are mounted by default to secure rear field of vision of operation.

* Beacon lamp is optional.



Operator presence sensing system Option

The OPSS restricts driving, lifting, and tilting in when the operator leaves the driver's seat in order to prevent safety accidents.

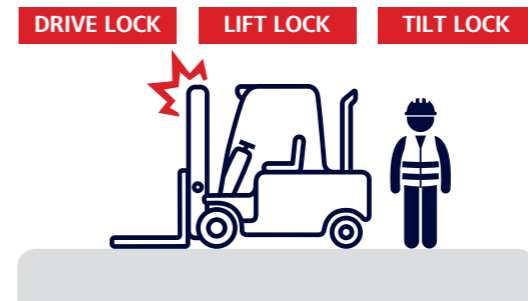

Rear Grip Bar & Horn Option

The rear steering wheel with horn embedded allows the driver to keep a stable, convenient posture during rear driving and operate the horn rapidly without changing the driving posture in case of an emergency situation.



Fork safety features

As the forks are being lowered, a down-control valve maintains a controlled descent speed. The down-safety valve prevents forks from dropping down in case of sudden damage of hydraulic line.

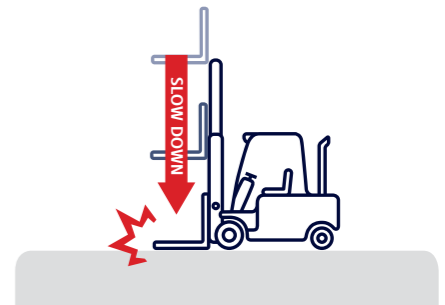

Grammer Seat Option

The full suspension seat of Grammer of Germany has an adjustable cushion depending on the weight of the driver, and convenience specifications such as seat belt switch, arm rests, and heater are optional.



* Semi-suspension seat is applied by default.

Various electric interlocks

Parking electric interlock

Operation of forklift truck is limited when applying the parking brake to prevent safety accidents that may take place due to the unintended operation of forward/backward levers by the operator.

Engine Starting at Neutral Position

The engine will start only with the forward and reverse levers kept at neutral positions to prevent safety accidents that may take place when starting the engine with such levers kept at forward or reverse positions.

MAINTENANCE ^{UP}

Easy maintenance, cost-effective service

Stay satisfied even after completing your work

LAGER MAINTENANCE SPACE

A large work space is provided for the follow-up management of consumables and major functional parts when you remove the engine compartment cover supported with two gas springs tool-less type side cover and floor plate.



Transmission maintenance

As the major functional parts of transmission, the control valve and filter are mounted on top of transmission to reduce the maintenance hours. Transmission is accessible when removing the engine hood and floor plate of tool-less type.



Detachable radiator cover

The plastic tool-less radiator sub-hood on top of the counterweight separated from the main hood reduces the downtime for checking the cooling water level and makeup.



Snorkel type air intake & Dual element

Snorkel-type air intake structure and large-capacity air cleaner measuring 6" are applied to keep the inflow of dusts from the ground into the air cleaner during operation, thereby extending the maintenance interval of the air cleaner.



Brake oil reservoir

Oil reservoir is mounted on top of the dashboard for the convenient management of brake oil, which should be frequently inspected and made up for safe operation.



Centralized fuse holders

Fuse is an item demanding the most frequent maintenance works among the components of the electric system of the forklift truck. All of the fuses are centralized on the front of the dashboard for convenient inspection and replacement of fuses.



Standard & Option

	Part	All
POWER TRAIN & CHASSIS	Mitsubishi S4S Diesel Engine	●
	F1/R1 Power shift Transaxle	●
	Hydraulic Power Steering	●
	Vertical Muffler	○
	Nissan K25 LPG Engine	●
	Bi-Fuel	○
	LPG Clamp - Swing Out, Swing Down	○
	LPG Empty Alarm	○
OPERATION ROOM	LPG Tank	○
	Head Guard(2075mm)	●
	Cabin	○
	Cabin Top, Front + Rear + Top + Wiper	○
	Air con, Heater	○
	Hood Insulation	●
	Convenience Tray	●
	Semi Suspension Seat + Belt	●
SAFETY	Suspension(Grammer) Seat + Belt	○
	Panorama Mirror + RH, LH Side Mirror	●
	OPSS - Drive , Drive + Mast	○
	Fire Extinguishers(1.0kg)	○

	Part	All
MAST & ATTACHMENT	2 Stage Standard mast(3000mm)	●
	Various Option Mast - 2, 3 Stage	○
	1070mm(2.5Ton), 1050mm(3.0/3.5 Ton) Fork	●
	Various Option Fork(1200 ~2120mm)	○
	Carriage - Hook(1100mm)	●
	Carriage - Hook Wide(1400mm) : Double Tire	○
HYDRAULICS	Integral S/S, Integral S/S+ Fork Positioner	○
	Side Shifter, Hinged Bucket, Rotating Fork, Paper Roll Clamp	○
TIRE	MCV 2 Spool	●
	MCV 3, 4 Spool	○
VISIBILITY	Single Pneumatic	●
	Double Pneumatic	○
	Solid, Non marking Tire - Single/Double	○
	LED Working Lamp - Front	●
CONVENIENCE	LED Working Lamp - Rear	●
	Turn Signal Lamp	●
	Beacon Lamp	●
OTHERS	Load sensor	○
	Rear Horn & Grip Bar	○
	Rear Tire Cover	●

● STD / ○ OPT

Specification

IDENTIFICATION								
1.1	Manufacturer		Hyundai					
1.2	Manufacturer's type designation		25DE-7	30DE-7	35DE-7	25LE-7	30LE-7	35LE-7
1.3	Drive: electric(battery or mains),diesel,petrol,fuel gas>manual		DIESEL	DIESEL	DIESEL	LPG	LPG	LPG
1.4	Type of operation:hand,pedestrian,standing,seated,order-picker		seated	seated	seated	seated	seated	seated
1.5	Load capacity / rated load	kg	2,500	3,000	3,500	2,500	3,000	3,500
1.6	Load center distance	c mm	500	500	500	500	500	500
1.8	Load distance, center of drive axle to fork	x mm	473	473	473	473	473	473
1.9	Wheelbase	y mm	1,650	1,700	1,700	1,650	1,700	1,700
WEIGHTS								
2.1	Service weight(including battery)	kg	3,815	4,223	4,595	3,732	4,139	4,512
2.2	Axle loading, loaded front	kg	5525	6371	7057	5503	6293	6979
	Axle loading, loaded rear	kg	751	852	1037	729	846	1033
2.3	Axle loading, unloaded front	kg	1614	1654	1553	1529	1576	1476
	Axle loading, unloaded rear	kg	2201	2569	3042	2203	2563	3037
WHEELS, CHASSIS								
3.1	Tires:solid rubber, superelastic, pneumatic, polyurethane		Pneumatic	Pneumatic	Pneumatic	Pneumatic	Pneumatic	Pneumatic
3.2	Tires size, front		28X9-15-14PR	28X9-15-14PR	28X9-15-14PR	28X9-15-14PR	28X9-15-14PR	28X9-15-14PR
3.3	Tires size, rear		6.00-9-10PR	6.50-10-10PR	6.50-10-10PR	6.00-9-10PR	6.50-10-10PR	6.50-10-10PR
3.5	Wheels, number front x rear (x=driven wheels)		2x2	2x2	2x2	2x2	2x2	2x2
3.6	Track width, front	mm	1005	1,005	1,005	1005	1,005	1,005
3.7	Track width, rear	mm	980	980	980	980	980	980
BASIC DIMENSIONS								
4.1	Mast / fork carriage tilt forward / backward	degrees	6 / 10	6 / 10	6 / 10	6 / 10	6 / 10	6 / 10
4.2	Lowered mast height	h1 (mm)	2,040	2,040	2,040	2,040	2,040	2,040
4.3	Free lift	h2 (mm)	150	155	155	150	155	155
4.4	Lift height	h3 (mm)	3,005	3,005	3,005	3,005	3,005	3,005
4.5	Extended mast height	h4 (mm)	3,465	3,465	3,465	3,465	3,465	3,465
4.7	Overhead load guard(cab) height	h5 (mm)	2,170	2,170	2,170	2,170	2,170	2,170
4.8	Seat height / standing height	h7 (mm)	1,186	1,186	1,186	1,186	1,186	1,186
4.12	Coupling height	h10 (mm)	283	299	299	283	299	299
4.19	Overall length	l1 (mm)	3,685	3,740	3,815	3,685	3,740	3,815
4.20	Length to face of forks	l2 (mm)	2,635	2,690	2,765	2,635	2,690	2,765
4.21	Overall width	b1 (mm)	1,220	1,220	1,220	1,220	1,220	1,220
4.22	Fork dimensions(hook type)	l x e x s (mm)	1,050x100x45	1,050x125x45	1,050x125x45	1,050x100x45	1,050x125x45	1,050x125x45
4.23	Fork carriage ISO 2328, class / type A,B		II / A	III / A	III / A	II / A	III / A	III / A
4.24	Fork-carriage width	b3 (mm)	1,102	1,102	1,102	1,102	1,102	1,102
4.31	Ground clearance, loaded, under mast	m1 (mm)	145	145	145	145	145	145
4.32	Ground clearance, centre of wheelbase	m2 (mm)	189	189	189	189	189	189
4.33	Aisle width for pallets 1,000x1,200 crossways(LxW)	Ast (mm)	3,981	4,066	4,102	3,981	4,066	4,102
4.34	Aisle width for pallets 800x1,200 lengthways(WxL)	Ast (mm)	4,181	4,266	4,302	4,181	4,266	4,302
4.35	Turning radius	Wa (mm)	2,310	2,395	2,430	2,310	2,395	2,430
PERFORMANCE DATA								
5.1	Travel speed, loaded/ unloaded	km/h	16/15.5	16/15	16/15	16.5/16	16.5/15.5	16.5/15.5
5.2	Lift speed, loaded/ unloaded	mm/s	550/660	450/550	450/550	500/600	420/500	420/500
5.3	Lowering speed, loaded/unloaded	mm/s	580/460	480/350	480/350	550/450	480/380	480/380
5.6	Max. Drawbar pull, loaded	N	19,276	19,325	19,355	18,640	18,680	18,708
5.8	Max. Gradeability, loaded	% (°)	29	25	22	28	24.5	22
5.10	Service brake		Drum brake	Drum brake	Drum brake	Drum brake	Drum brake	Drum brake
ENGINE								
7.1	Engine manufacturer / type		MITSUBISHI / S4S	MITSUBISHI / S4S	MITSUBISHI / S4S	NISSAN	NISSAN	NISSAN
7.2	Engine power acc. to ISO 1585	kW/rpm	35.3/2,250	35.3/2,250	35.3/2,250	35/2,550	35/2,550	35/2,550
7.3	Maximum torque	kgf.m/rpm	18.0/1,700	18.0/1,700	18.0/1,700	17.7/1,600	17.7/1,600	17.7/1,600
7.4	No. of cylinder / cubic capacity	EA/cc	4/3,331	4/3,331	4/3,331	4/2,488	4/2,488	4/2,488
7.5	Oil volume	ℓ	6.5	6.5	6.5	3.5	3.5	3.5
OTHER DETAILS								
8.1	Operating pressure(system / attach)	bar	210/160	210/160	210/160	210/160	210/160	210/160
8.2	Attach oil volume	ℓ	30 (60 MAX.)	30 (60 MAX.)	30 (60 MAX.)	30 (60 MAX.)	30 (60 MAX.)	30 (60 MAX.)

Dimension

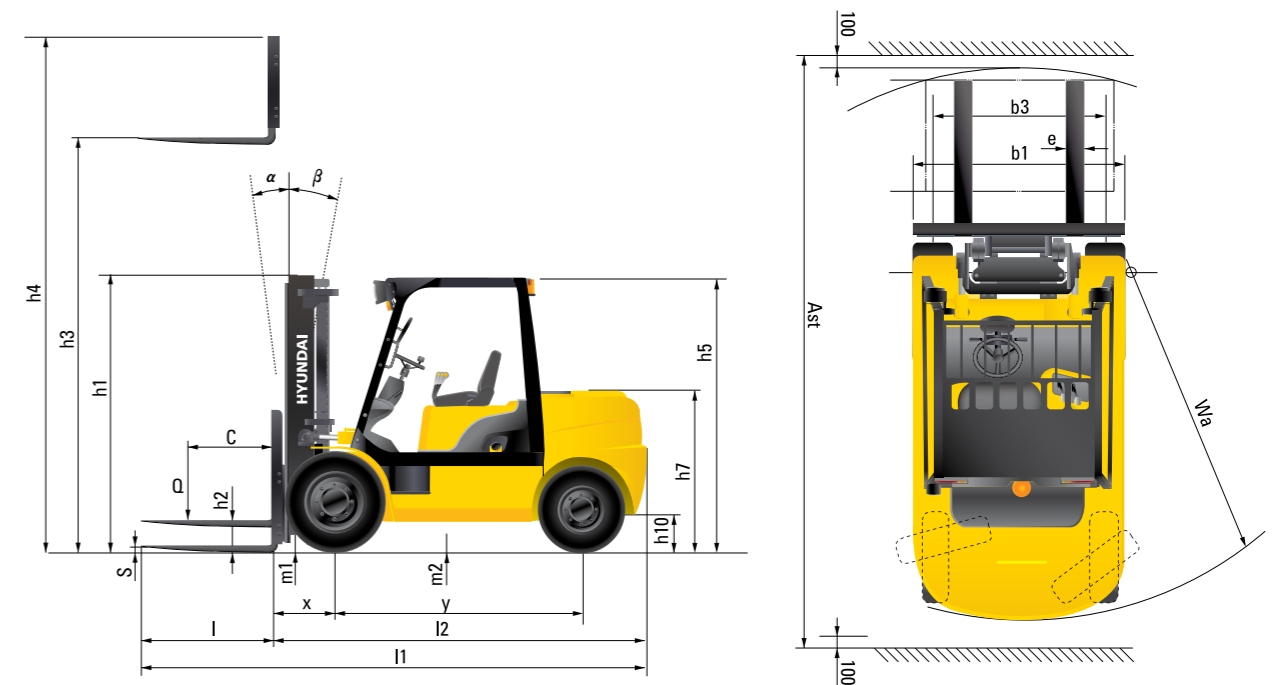

Load Capacity

